

3-SIDED RAIL DOCK SHELTER SPECIFICATION SHEET

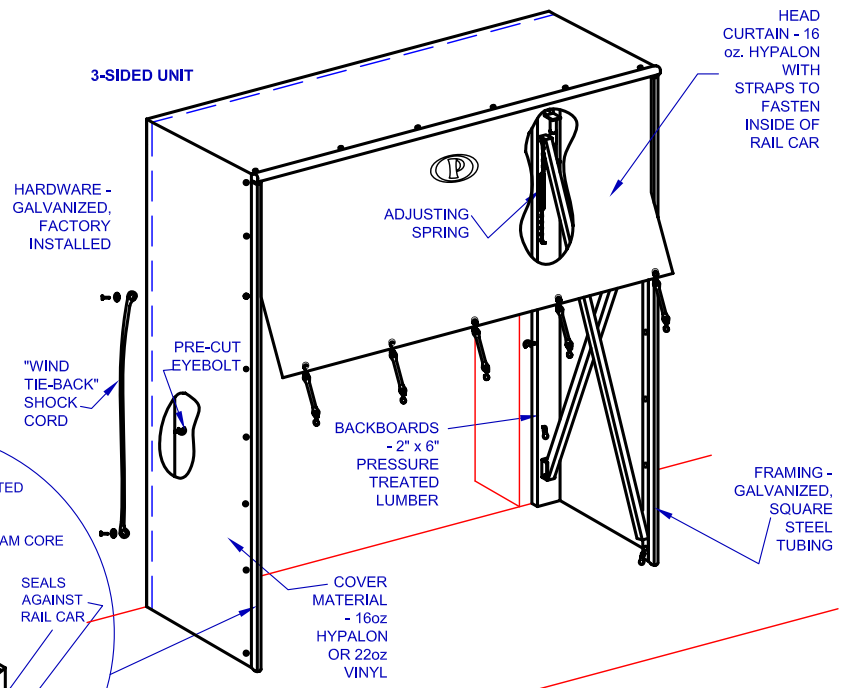

NOTE: WHEN NOT IN USE, UNITS MUST BE RETRACTED.

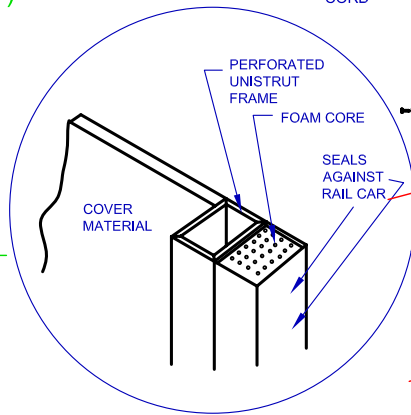
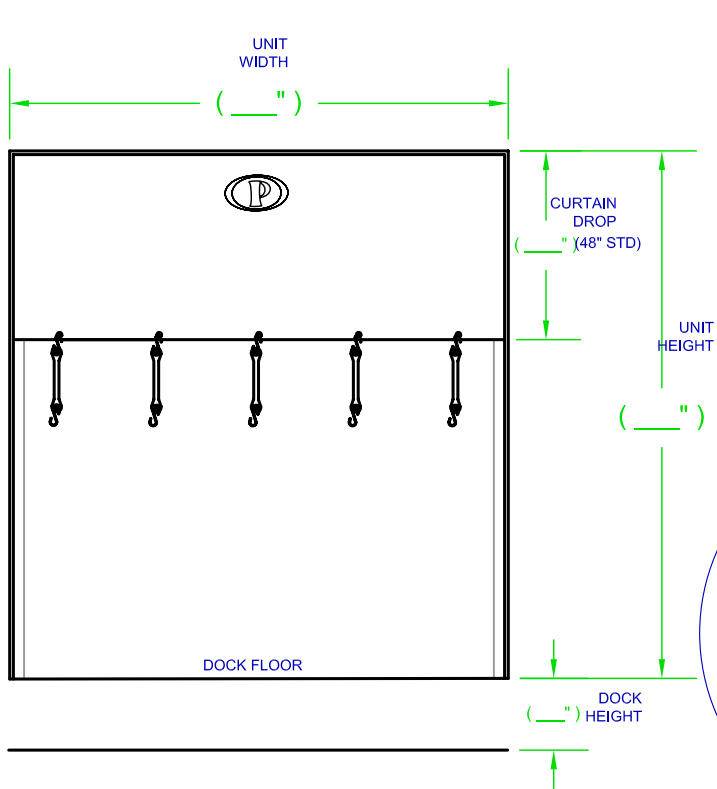
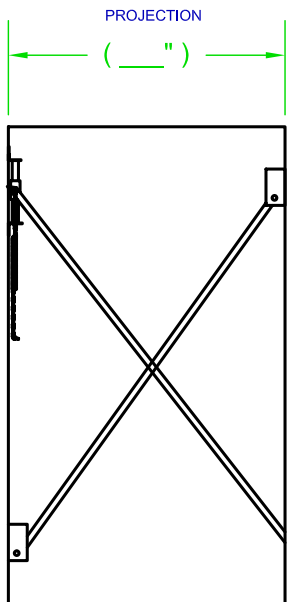

QUANTITY: _____

UNIT WIDTH: _____ HEIGHT: _____

PROJECTION: _____

HEAD CURTAIN OFF RAIL: _____
(Standard 11'-0" off rail)

UNIT TO EXTEND BELOW DOCK: _____

NOTE: 4-sided Unit **must** extend a minimum of 12" below dock. It is also recommended, but not mandatory, to extend 3-sided unit 12" below dock to reduce bottom draft.

DOOR SIZE: _____ WIDTH _____ HEIGHT

DOCK HEIGHT: _____

DISTANCE FROM WALL TO - CENTERLINE OF TRACKS: _____

INSIDE OF NEAR RAIL: _____

LEDGE or PLATFORM PRESENT: YES NO

IF SO, DESCRIBE: _____ W x _____ H x _____ PROJECTION

SPECIAL INFORMATION

PERMA TECH, INC.
 363 HAMBURG STREET • BUFFALO, NY 14204
 (716) 854-0707 • 1-800-DOC-SEAL

JOB: _____

DEALER: _____

CONTACT: _____ QUOTE #: _____

APPROVED BY SIGNATURE: _____